

- Thank you for your purchasing **Robstep**.
- **Robstep** is an intelligent robot that balances automatically.
- **This User's Manual** providing you information about how to assemble and safely use the **Robstep**, and how to maintain it . If you want to get the most pleasure out of your **Robstep** , please read it carefully.
- It is critical that you know of all safety notices and precautions before your first ride.

Robstep

User`s Manual

This User's manual applies on all smart balanced robots named **Robstep** which are produced by Robstep



WARNING!

- **To avoid the possibility of losing control, collision or suffering a fall, we insist that all customers should learn how to use Robstep securely and safely.**
- **This User's manual provides you all needed information about safety video and road senses.**
- **It is suggested that all consumers should adhere to instructions mentioned in the User's Manual, otherwise, consumers should bear full responsibility for all consequences. We will not liable for accident caused above and will reserve the right to the legal responsibility.**
- **For further related service support, please contact with the local agent.**
- **More information ,please refer on our website :www.robstep.com.**

Catalogue

Catalogue.....	3
1. Document overview	1
1.1 Document overview.....	1
1.2 User’s Manual	1
1.3 Related directions	1
2. Introduction	1
2.1 Illustration about vehicle types	1
2.2 How to record the serial number of Robstep ?	1
2.3 How Robstep work ?	2
3. Assembly Instruction.....	2
3.1 Double check the spare parts inside the packing	2
3.2 Installing Robstep.....	2
4. Controlling of Robstep and the display board	3
4.1 Remote control of Robstep	3
4.2 Pedal sensor	3
4.3 Display board	4
5. Instructions of battery of Robstep	4
5.1 Low power	5
5.2 Charging steps	5
5.3 Overheating and slow operation at higher temperatures.	5
5.4 Precautions of battery transportation.....	6
5.5 Specification of battery of Robstep.....	6
6. Safely using	6
6.1 The weight limit of users	7
6.2 The maximum driving distance	7
6.3 Speed limit	7
6.4 Vibration warning	8
7. How to use Robstep	9
7.1 Start Robstep.....	9
7.2 Safe Parking.....	9
7.3 Driving steps.....	9
7.4 Driving practice.....	10
8. Driving safety instruction	10
9. Repair and maintenance	12
9.1 Carrying Robstep	12
9.2 Wheels maintenance	12
9.3 Cleaning.....	12
9.4 Storage	12
10. Technical Parameters.....	13
11. Robstep dimension	14
12. Fault handling.....	14

1. Document overview

1.1 Document overview



- Introduce the detailed function and features
- Description about safety and warning information
- **Robstep'** parts list
- Procedures about assembling **Robstep**
- Precautions about safe driving
- Driving skills

1.2 User's Manual

- User's Manual will help you assemble and install **Robstep** correctly and efficiently, please read the user's manual for further information.
- Security video tutorial and the user's Manual in form of PDF can be downloaded from the website www.robstep.com. To avoid dangers, please make sure that you follow all instructions provided from the video.
- Please use the software named Adobe Reader to open the PDF document. (visit www.adobe.com for download).

1.3 Related directions

Explanations provided below applied on this whole user's manual only.

 WARNING	Warning: Any misfeasance could increase the risk of physical threats.
 NOTE:	Note : Precautions and use-method that should be noticed by all users.

2. Introduction

2.1 Illustration about vehicle types

- **Robstep** is a kind of intelligent robot researched and developed by **Robstep**, which made the usage of principle of mobile equilibrium for controlling of moving forward, backward and stop. With the tilting of your body, you can control its speed and direction freely.
- **Robstep** is very flexible, safe and portable.
- **Robstep** has been widely used in various aspects of work and life, such as personal transportation, working patrol, indoor venues, tourism entertainment and car carrying and so on.

2.2 How to record the serial number of Robstep ?

- The serial number of **Robstep** is unique and exclusive. Serial number is important for quality tracing, insurance claim, claim of missing.
- Acquiring the serial number at the outer box of the package.

- The serial number consists of eleven number or letter in total, please ensure that you have it record and keep it well.

2.3 How Robstep work ?

- **Robstep** consists of main body, wheels, electric drive system, etc. The wheels are assembled on the two sides of the main body, the power source ,the control circuit ,drive circuit ,sensor and control switch are assembled inside the main body .The speed sensor and angle sensor are connected by swing joint. They work together to transmit information to the control circuit regarding to the intersection&inclined angle of the wheels and the main body,. Therefore, with the above actions and the software inside calculating the torque and the running speed so that **Robstep** can be balanced itself.
- It works like human body in that the moment you move forward you have to step forward to keep balance. In other words, when you stand up on the **Robstep**, the power device will make its wheels lean forward or backward so that you won't fall down.
- Regarding to the car handlebar, when you lean it on your right gently, it turns right; when you lean it on your left, it turns left. But when you make it stands vertically, it will keep the direction straightly all the time.
- We suggest that all users should lean right or left when he/she leans the handlebar respectively. Because the inertial dynamic system inside can only control the direction of forward and backward instead of right and left. Therefore, to avoid centrifugal forces in turning and increase the security of riding **Robstep**, we recommend that users should take the above advice seriously.

3. Assembly Instruction

In this part, we will talk about the parts of Robstep and how to install Robstep.

3.1 Double check the spare parts inside the packing

Please check the package of **Robstep** and make sure that all spare parts are complete. The spare parts of **Robstep** are listed as follows, if any of them missing, please contact with the local agent or us directly.

- | | |
|-------------------------------------------------------------------------|-------------------------------------|
| 1) Main body | 6) Two remote keys |
| 2) Handlebar grip | 7) User's Manual, and warranty card |
| 3) Handlebar stem | 8) Product quality certificate |
| 4) Charger | |
| 5) Tool and screws bag (which contains of erecting tools and 10 screws) | |

3.2 Installing Robstep.

Step 1: put the handlebar grip into the adapter of the handlebar stem and tighten it up with 4 pcs of M5 screws as follows. and install it according to the instruction by the arrows with same color.

Step 2: put the handlebar stem into the adapter and tighten it up with 4pcs of screws as follows.

Step3: press the power-open button behind the main body of **Robstep** to turn it on.



- Please make sure that the power is off when you conducting any maintenance or installation of Robstep.

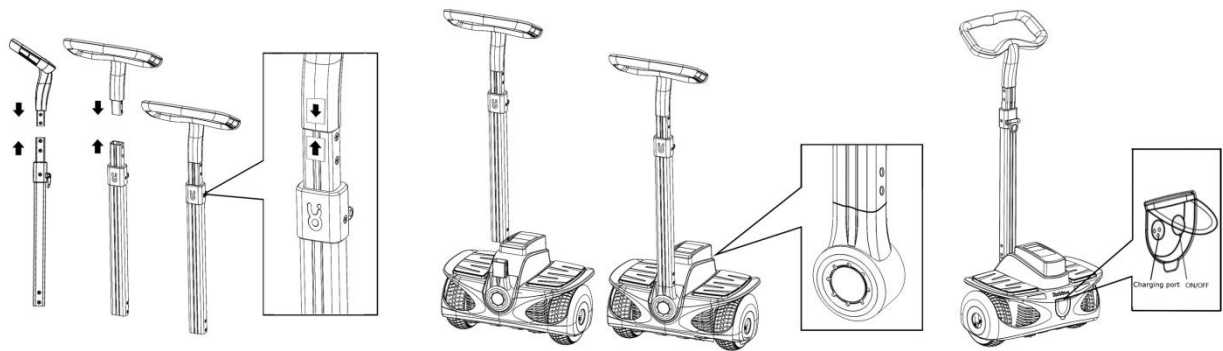

4. Controlling of Robstep and the display board

4.1 Remote control of Robstep

Remote control of **Robstep** is a long-distance equipment of controlling, you can make a control of **Robstep** within 10 meters.

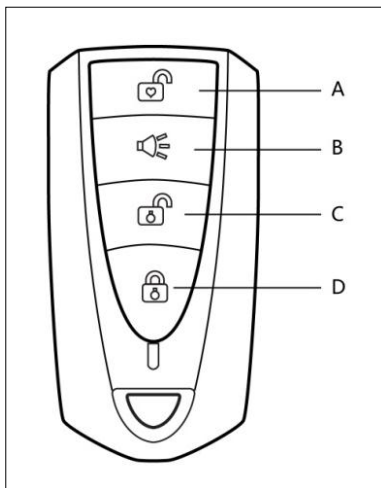

- **A: the beginner mode.** Pressing this button so you can enter into the beginner model whose speed limits within 7km per hour. If you don't use it for more than 10minutes, then **Robstep** will shut down automatically.
- **B: warning and locking mode.** Pressing the button **Robstep** can keep locked and give bummer and vibrating while someone else attempts to move it. If you want to unlock it, just press it again. However, if you keep the **Robstep** in the state of bummer within 18 hours, it will turn off automatically.
- **C: normal mode.** You have to turn off the beginner mode when you want a normal mode. Turn off the power and then turn it on so you can enter into the second mode with speed limit within 15km per hour.

- **D: shutdown.** Press the button and **Robstep** will be power off. In this mode, the system will auto enter into the state of deep shutdown if leave **Robstep** for more than 18 hours, as for power saving, Then you should press the power button in the back of the main body to restart the **Robstep**, And it can be power on again by the remote key. If you long press the off button under the state of shutdown, the system will cut down the main power automatically, and also enter into the state of deep shutdown. Press D" shutdown" button again during power off mode, system will cut down the main power automatically. In order to save more power. Press the button beyond charging gate will power **Robstep** on.

- **A + C : under unmanned mode.** press button A for 3 seconds(the buzzer will make a sound of tick) , then press button C in the following 3 seconds, **Robstep** can enter into self-checking system. Before the start of self-checking, the body of **Robstep** shall be hung up. In the state of self-checking, you will hear the bummer sound and all five lights keep flickering. The system of **Robstep** itself will conduct a series of self-checking, in the meanwhile, the wheels will turn on automatically in a slow speed. If there is no problem after self-checking, the system will shut down normally. Otherwise, warning sound of beeping will come from the buzzer and it will turn off automatically. Under this condition, we insist that you should send the **Robstep** to your local agent or contact with us directly.

4.2 Pedal sensor

There are four sensors under the pedal, any of them stepped upon by users, Robstep will enter into the balance model automatically.



WARNING

- Please make sure that your feet are standing on the pedals while your first riding.
- Please don't put any objects on the pedals in that it will keep the system opened and increase the possibility of collision and even damage to Robstep, and cause physical injuries to users.

4.3 Display board

The display board of Robstep is fixed on the top of the battery. It shows information about Robstep during riding.

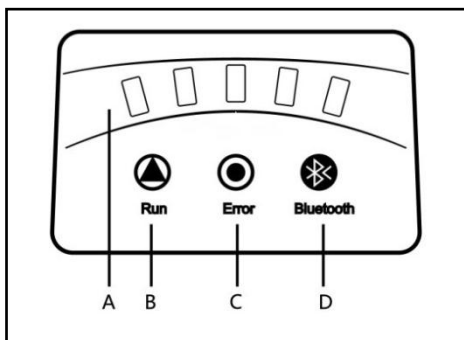

A: Display board of electrical quantity. Normally, all five lights will keep brightening when the power is sufficient. Five lights means **Robstep** is fully charged, four means there is 60 % ~80% power left.

B: The green indicator light. It will keep shining when it's under the opening mode which means the system is under a normal state, otherwise, it will turn off with indication which there is something wrong with the system.

C : The red indicator light. When you see the indicator light turn red, that means the system goes wrong and you should seek help from the local agent or contact with us directly.

D: Indicator light of Bluetooth.

5. Instructions of battery of Robstep

This part mainly describes how to charge Robstep at home, how to take good care of the battery, needed precautions and battery specification.



NOTE:

- To protect your safety and maximize the service life of battery, please operate it under the following instructions.
- Please recharge Robstep when it's power off.
- Please make sure that there's 100% power of Robin before storage and recharge it at least every three month .
- To avoid over discharge, the battery should be recharged in time or at least within two days when it's power off.
- Please step off Robstep when it's almost power off and the alarming sound's beeping, recharge Robstep in time before second usage. Please do not use Robstep when it's under recharging in that it might cause bad influence to the battery life and accident.
- Please stop using Robstep if any of these happens: peculiar smell comes out of the main body or it's overheated; any leaking materials come out of Robstep.
- Only technicians can make maintenance with the battery.
- Don't let children and animals touch the battery in case of any injuries. Make sure that the power line is off from Robstep before riding and don't do anything with Robstep while it's charging.
- There are toxic substances inside the battery, so never be attempted to open it or unclench it with any equipments or even put any other material into the battery.

-
- Don't touch any leaking material comes from Robstep.
 - Only equipments provided by us can be applied on the charging of Robstep.
 - The battery of Robstep can only put into usage under the admission of the local law.
-

5.1 Low power

Please stop riding Robstep when the battery shows power low. At the time, the system will gradually slow down, and within 7 seconds shut down automatically. If you insist the riding, you may fall from Robstep and get injuries and cause damage to the battery.

5.2 Charging steps

- Open the charging port of **Robstep**.
- Make sure that the charging port is dry.
- Plunge one side into the charging port of **Robstep** and the other side into the electric power source.
- It is fully charged when the red lights on the charger turns into green. Please stop charging. Charging too long might affect the lifetime of the battery.



- Please use the standard plug of your community or country.

● Please recharge and store the battery according with the instruction, otherwise, the battery will be damaged and bad influence upon the battery life caused.

- Charging time of Robstep is about 4 hours, power will be off automatically when it's fully charged.
 - The lifetime of the battery is limited. Generally, the battery can be recharged for 500 times. When the battery is recharged more than 500 times, the usage time of Robstep will decrease dramatically even it's of full power.
 - Please recharged Robstep every time before usage because the battery is losing power even it's not under using.
 - The battery can be recharged even there's still power inside Robstep.
 - For better usage of the Robstep, an ambient temperature range of 10-30°C is highly recommended in order to make full use of battery.
 - After a long time use of battery, it is normal if the battery getting hot.
 - The travel distance will become shorter in cold places even when the battery is fully charged.
 - Keep the environment dried and clean during charging.
 - Never put the plug into the charging port if you find it wet.
 - Do not put the battery in the fire or heat it, and no storage in high temperature is allowed.
 - It's strictly forbidden to insert the conductive objects into the charging port, or the electronic equipment in the car body will be damaged for short circuit.
 - Do not put the battery in the water, and keep it from wetness when it needs to be stored.
 - Do not disassemble the battery and change the battery structure.
-

5.3 Overheating and slow operation at higher temperatures.

- In order to keep the efficiency operation high, please ensure that the battery. temperature remain within certain ranges specified in the instructions. In case of overheating during riding, the system will make a safety warning.
- Please keep the temperature in certain area before charging or during charging. The efficiency of

operation will be best when the temperature near the recommended degrees, otherwise, it might lengthen the charging time.

5.4 Precautions of battery transportation



- **Lithium battery is considered to be toxic material by most countries, make sure that you are lawfully permitted before you transport it to any other places.**



- **If you intend to transport the battery by flight or any other types of shipping, please contact with the local authorized agent or us for inquiries information about transportation of hazard material.**

5.5 Specification of battery of Robstep

Battery type	Lithium battery
Charging time	About Four hours
Voltage	48 V
Weight	3.1kg (for reference, Detailed see the actual weight)
Beginning volume	8mA
Size	165mmX145mmX 85mm
Operating temperature	-10°C~50°C (recommend 10°C~30°C)
Charging temperature	-10°C~50°C (recommend 10°C~30°C)
Storage(10°C~30°C)	3 months (Need fully charge before storage)
Storage relative humidity	5%~95%

6. Safely using

- **Robstep Robot Co., LTD** hopes all users can drive **Robstep** safely and enjoy it. Remembering that how you learn biking, driving a car, skiing or using other similar traffic tools , all these experience can be applied to our products.
- Please follow all instructions from the "User's Manual" and "Safety videos" so that you can drive **Robstep** safely. Please check whether the tires are damaged or not, whether the components loosen or not before your driving every time. Any unusual condition, please contact with local agents for help in time.



- Please read "User's Manual" and watch "Safety videos" carefully, from which you can get a lot of important safety information, including speed limit, vibration warning and

safe shutdown, etc.

- You must install every component reasonably before using Robstep, avoid product damaging,
 - Please don't use Robstep to do anything which might endanger personal safety and property safety.
 - Please don't modify Robstep's components, which may affect the performance of Robstep, even damage Robstep. Meanwhile it may cause other serious damage.
-

6.1 The weight limit of users

- The reasons for weight limit are as follows:
 - Ensure users' safety.
 - Reduce the damage caused by overweight.
 - The maximum weight limit of driver: 100kg.
 - The minimum weight limit of driver: 35kg.
-



- You may fall down from Robstep if it is overweight.
-

6.2 The maximum driving distance

The maximum driving distance is related to all kinds of factors, for example:

- Terrain: The driving distance will be increased when driving on the smooth and flat surface, otherwise the driving distance will be reduced.
- Speed and driving style: maintaining moderate speed will increase driving distance. On the contrary, the frequent start-up and stop, acceleration and deceleration will reduce driving distance.
- It will reduce the driving distance if the driver is somehow overweight, and vice versa.
- Storing, charging and driving **Robstep** within the recommended temperature will increase the driving distance, and vice versa.
- Reasonable charging and maintaining the battery will increase driving distance, and vice versa.
- A free wind driving can increase driving distance, and vice versa.

6.3 Speed limit

- The handlebar of **Robstep** will lean to the driver when it approaching the maximum allowable speed, which reminding you that you should stop accelerating. The buzzer will give out alarm sound when you back too fast to the retreat limit speed, reminding you that you should slow it down or make it forward.
- **Robstep** can keep balanced well within the stipulated speed. The handlebar will lean to the driver's body when its speed is to surpass the stipulated speed in order to remain a safe speed.
- Please keep a safe distance between your body and the handlebar.

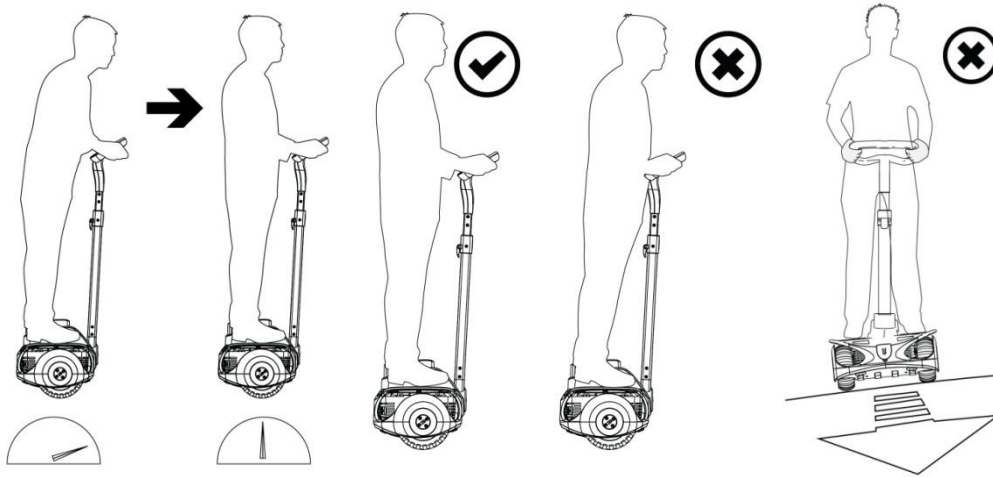

i NOTE:

● Please don't drive or make any turning on the transverse slopes , which will lead to the shifting of balance angle of Robstep and result in uncomfortable driving experience.

6.4 Vibration warning

- **Robstep** will send warning message by vibrating under the following situations:
 - (1) a motion alarm starts sounding if a thief pushes the locked car around;
 - (2)over speeding when you lean backward;
 - (3)any attempts of stepping upon **Robstep** during charging.
- Please stop using **Robstep** when it is under (2)&(3) situations listed above.
- Please stop to start **Robstep** immediately and get down from **Robstep** when it strongly vibrates in the driving process ,and do not try to step on again.

! WARNING

● **Robstep** can keep balance for one second itself after the users getting down from it.

7. How to use Robstep

You need to note some related safety matters before driving Robstep. It is very important for you to understand all safety matters mentioned inside the user's manual.

7.1 Start Robstep

- If it is your first time to start **Robstep**, please press the button on the back cover of **Robstep** Body.
- Then you can turn on and off **Robstep** by using wireless key directly.

7.2 Safe Parking

- When there is an incorrect operation or the power consumption reaches the minimum quantity within normal driving, the system will then generate a secure parking information, meanwhile **Robstep** will have a high-frequency vibration, then **Robstep** can automatically slow to a stop.



- **When the battery is exhausted or the system tells a safe parking information, please don't continue to drive Robstep, otherwise Robstep can't keep the equilibrium because of power shortages, in which case the user is likely to be injured.**

- **If the battery power reaches the minimum limit and the user continues to drive Robstep, the battery life and its capacity will be affected.**

7.3 Driving steps

- **Step 1: Starting Robstep**

Press the button of the back cover to start **Robstep**, then you can see the indicator lighting. Indicator flashing indicates the start is normal.

- **Step 2: pre-commissioning on the Robstep**

There are four sensors under the pads, which can sense whether the user is on the **Robstep** or not. According to the tilt relation between the **Robstep** and user, there are three situations:

(1) **Robstep** tilts more, the user puts one foot on the pad at this time, then **Robstep** will shake to tell the user the tilt angle is too large, please don't get on **Robstep**;

(2) **Robstep** tilts less, the user puts one foot on the pad at this time, **Robstep** can quickly and automatically balance to the vertical posture after the sensors sense the user. The buzzer gives out "drip" sound, which indicates that the system has entered the manned work mode.

- **Step 3: Get on Robstep, control Robstep forward and backward**

Put one foot on **Robstep** gently first, then the other foot. The user should keep the balance of body gravity when standing on **Robstep**, which can make **Robstep** keep motionless. Lean your body gently forward or backward to make **Robstep** forward or backward, please remember the body amplitude is not too big.

- **Step 4: Control Robstep to turn left or right**

Lean the handlebar left or right to make **Robstep** turn left or right.

- **Step 5: Get off Robstep**

Keep **Robstep** motionless and balanced before getting off from it. Get off one foot first, then the other one.



- **Please don't shake the handlebar violently, which can increase the probability of accidents.**
- **Please gently lean the handlebar to turn right or left.**

7.4 Driving practice

When you want to drive Robstep outside, for your safety, please make sure you have already been skilled in driving Robstep:

- Please practice driving **Robstep** in the open field repeatedly, until you can easily get on, make forward or backward, turn, stop and get off.
- You can drive **Robstep** on narrow and winding ground by practice.
- If you can't be skilled in driving **Robstep**, please don't drive **Robstep** to places where are full of children, pedestrians, vehicles or obstacles
- If it is your first time to drive **Robstep**, please practice driving it in spacious and safe places.
- Please be careful when getting through the door.
- Please maintain the clearance of the wheels.
- Please note whether the ground is flat or not.
- You can drive **Robstep** on different terrains ,but you must slow it down in unfamiliar terrain. Please don't allow **Robstep** be off the ground at any time.
- **Robstep** is a complementary-type vehicle, which uses on the flat surface only. Users should make sure their hands in a vertical state when driving **Robstep** on uneven surface, making it to the direction you want to go by turning the handlebar and allowing the tires to follow the contours of the road when driving.

8. Driving safety instruction

This section provides some safety knowledge and warning, which helps you to understand the safety matters of driving Robstep effectively. In order to ensure you can drive Robstep safely, please make sure that you read through the "user's manual" and abide by the relevant safety instructions.

-
- It may cause some accidents such as losing control, collision and falling down when you drive **Robstep** at any time. In order to avoid accidents, you must read the user manual.
 - instructions carefully. Please ensure **Robstep** is in good condition, and use it after you have known all the content of user manual well.
 - When you drive **Robstep** , please ensure for the safety measures such as wearing helmet ,knee pad, elbow pad.
 - **Robstep** is only applicable to personal entertainment and it is not recommended to use as public transportation. It is banned to use on Motor lane.
 - Please don't drive **Robstep** on abrupt slopes.
 - Please don't let children ,the aged, or pregnant drive **Robstep**. Generally, we recommend that only teenagers who are more than 16 years old can drive **Robstep**.
 - Please don't drive **Robstep** after drinking or having drugs.
 - Please comply with the state and the local traffic regulations when driving **Robstep**.
 - The driver must confirm the moving speed is within a safe speed limit. Be ready to stop **Robstep** at any time.
 - Don't drive **Robstep** in places without enough light.
 - Please avoid driving **Robstep** on snow, iced surfaces or wet and slippery floor, etc.
 - Please avoid driving **Robstep** on surface full of sporadic objects like twigs, garbage or small stone.
 - Please avoid driving **Robstep** in narrow or impedimental places.
-

-
- Please avoid driving **Robstep** on any unsafe environments. Some dangerous places maybe cause a fire or explosion by flammable gas, steam, liquid, dust or fiber.
 - Please drive **Robstep** under a suitable environment. If you need to get permission from others, please make sure you've done that before your driving.
 - Please be alerted about your surroundings, maintaining a good vision will help you drive **Robstep** in a more safely way.
 - Please don't start or stop **Robstep** suddenly. Please do not drive **Robstep** backward at a high speed.
 - Clench the handlebar tightly, relax your legs, bend your knees slightly, these can help you keep balance when driving on the bump ground.
 - For a comfortable gesture, you can adjust the handlebar to a right height, and put the centre of your feet on the pads.
 - Please keep some distance from your body to the handle when you driving , Otherwise it can increase the possibility of losing control, collision and falling down if it is too close.
 - Please wear suitable sports clothes to drive **Robstep**, which will help you deal with emergency better.
 - Please remember that you will be 21 centimeters higher than your normal height when driving **Robstep**, so be noted that keep your head a little bit down when getting through the door.
 - Please note your body balance when turning , avoiding falling down from **Robstep** because of gravity shift or fast speed.
 - Please don't do other things when driving **Robstep** , such as telephoning ,listening to music or any other activities, which can affect your driving.
 - **Robstep** only can load one person at a time, please don't load two or more persons.
 - Please stay and wait for the relevant department personnel to handle events when some accidents happened in the driving process.
 - When you are driving **Robstep** with other drivers together, please keep certain distance to avoid collision.
 - Please don't start **Robstep** when the battery power off and **Robstep** automatic stop, If you restart **Robstep** it would be fall down because of it haven't enough power to keep maintain balance.
 - Please don't let hands off when **Robstep** is in equilibrium pattern .Because this action will make **Robstep** automatically forward for some distance, which may hurt others beside you or damage **Robstep**.
 - This personal vehicle is not designed or tested or proved to be medical treatment equipment, Therefore, all users must be capable of driving **Robstep** themselves.
 - Please don't exceed or below the maximum or minimum load on the User's Manual. If you exceed the load it would be losing control, balance and causing damage. If you less the minimum load it maybe can't work, especially can't reduce the speed or stop when driving on the slope.
-

9. Repair and maintenance.

Daily maintenance is necessary for Robstep. This section is mainly about how to maintain Robstep.



WARNING

- Please ensure the power and charging line are disconnected before carrying out the following operation.

9.1 Carrying Robstep

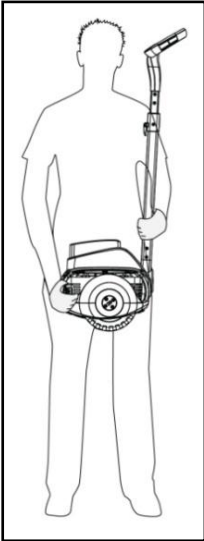

Raise and lower **Robstep** in the right way: If you want to carry **Robstep**, please follow the steps below:

- Make sure that **Robstep** is disconnected to charger and turned off.
- Clench **Robstep**'s pole root with one hand, then raise it with the other hand.
- Carry **Robstep** with your arms force.
- It's easy to carry **Robstep** with Parking holder-for vehicle.

9.2 Wheels maintenance

- Check the tire components, slosh the tires along the tire axle with your hand, and observe whether the tire components shaking or not: if yes, please check the screws in the tire components installation area and screw them tightly.
- Check whether the tyres wear badly or not, whether they wear uniformly or not.
- If the tyres wear badly, please contact with the after-sale service department for replacement.



NOTE:

- **Robstep will lock itself down and can't be turn on under the condition of running more than 35000km which is the total lifetime of it.**

9.3 Cleaning

Please note these matters before cleaning:

- Make sure **Robstep** is power off.
- Please wipe **Robstep**'s shell with soft dry cloth for cleaning.



WARNING

- Please avoid using water or other liquids to clean **Robstep**. If the water and the other liquids seep into **Robstep**, it will cause permanent damage to internal electronic components of it.

9.4 Storage

- Please store **Robstep** indoor, under dry and appropriate temperature place. If you won't use **Robstep** for a long time, please do not try to connect to the power. Because the battery will wear down with the time passing.

10. Technical Parameters

Model NO	Robstep	remarks
Maximum speed	15km/h	<p>*The running distance of 20km after single charging is tested under the condition of the environment for 25 degrees Celsius, 70 kg weight and flat road.</p> <p>* The actual values will be different according to the different circumstances.</p> <p>* These data are for reference only, please refer to the specific data under different environment.</p>
Distance(after single charging)	20km*	
Max climb capability	15 degree	
Total Weight	18.5 kg	
Min-Max load	35~100kg	
Min turning radius	0	
Dimension	467(length)/464(width)/1000~1400(height)(mm)(scalable)	
Battery	lithium, 8AH 48volt	
Power requirement	110/240volt 50or60HZ,universal	
Charging time	About 4 hours	
Tyre type	Vacuum tyre	
Full lifetime	35000km	

11. Robstep dimension

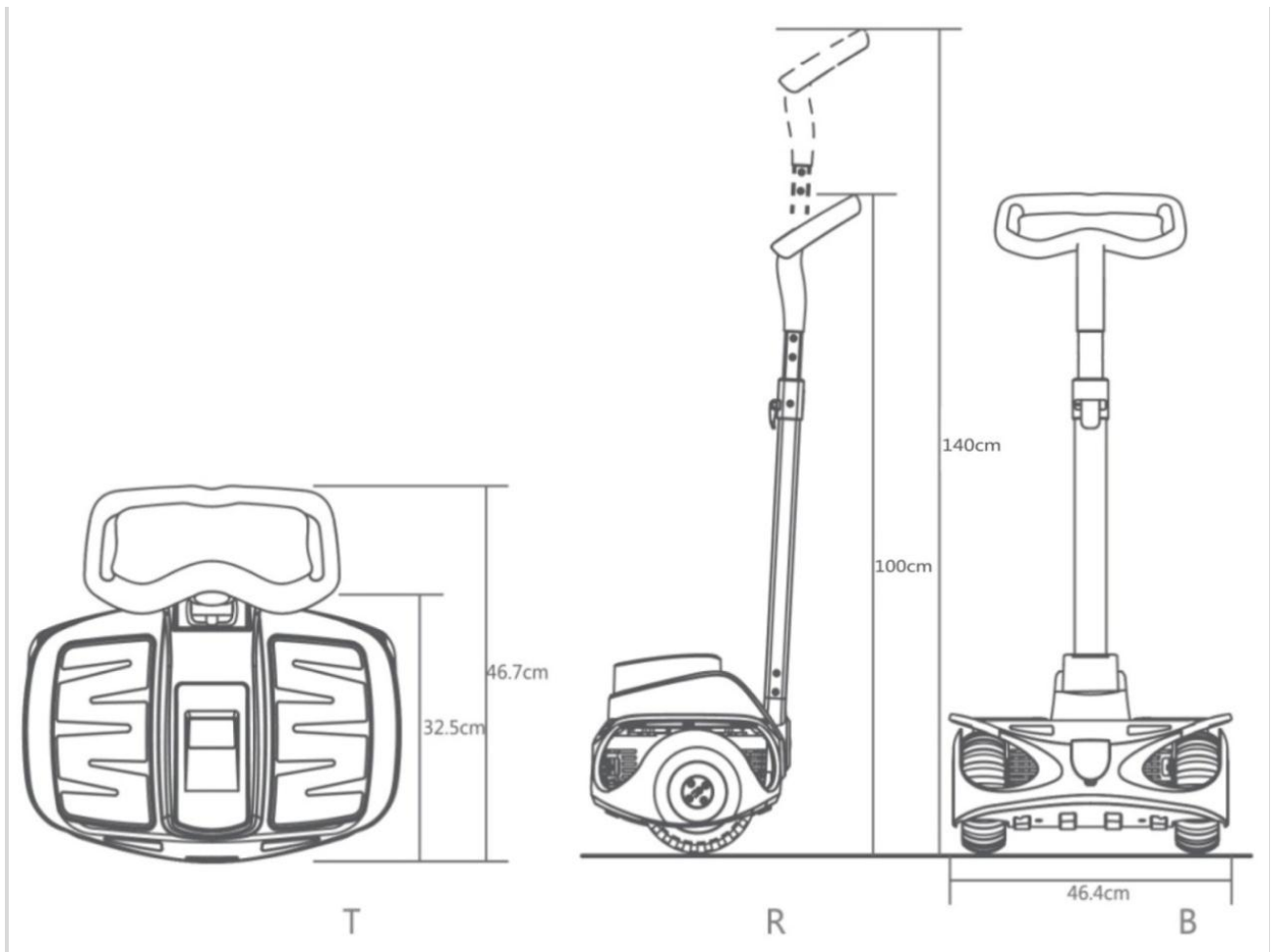

12. Fault handling

- Self-checking projects of **Robstep** include : the sensors, system static electricity, the system dynamic electricity, motor speed fluctuation etc.
- If there is something wrong with **Robstep** , please contact with the local agents or Robstep directly.



- About the information of the repair station , please visit our website : www.robstep.com ;
- or call the hotline: **(0086)0769-26620928**.

v1.4 printed in China.



Service centre of Robstep Robot Co., LTD , China

Address: Songhuhuake Industrial Park, No.6, Gongye nan Rd. Songshan Lake National High-tech Industrial Development Zone, China.

Tel: (0086)0769-26620928 .

Website: www.robstep.com
